



Rev. 10/16/12

Temperature and Humidity Transmitter

Wireless Temperature and/or Humidity

Features & Options

- 8 Year Battery Life (with two 3.6 volt lithium batteries, full AA size)
- Optional Temperature Setpoint and Occupant Override
- 100 Foot In-Building Range, Extendable to 1,000 Feet with Repeater*
- Transmitted signals can be converted to Voltage, Current or Resistive Outputs for the Controller

The BAPI Wireless Transmitter measures the room temperature and Humidity and transmits the data through 418MHz RF to a receiver. The transmitter is mounted in a BAPI-Stat 2 style enclosure and has an in-building range of 100 feet*. It is available with optional Temperature Setpoint and Occupant Override.

The unit has an estimated battery life of 8 years using two high-capacity 3.6V lithium batteries with a transmit rate of once every 10 seconds. Each transmitter has a unique address with built in error detection. Each variable sent by the transmitter is picked up by the receiver and converted by a BAPI Analog Output Module to a voltage, current or resistance signal for the controller.



Transmitter with optional Temperature Setpoint & Override

- PART #: BA/BS2-WTH** - Wireless Temp. and Humidity Transmitter
- PART #: BA/BS2-WTH-O** - Wireless Temp. and Humidity Transmitter with Override
- PART #: BA/BS2-WTH-S** - Wireless Temp. and Humidity Transmitter with Temp. Setpoint Adjustment
- PART #: BA/BS2-WTH-SO** - Wireless Temp and Humidity Transmitter w/ Temp. Setpoint & Override
- PART #: BA/LI3620** - Lithium Battery 3.6V

See end of Section F for list pricing.

Associated Products

• 418 or 900 MHz Receivers

Receives the RF signal from one or more transmitters or repeaters and outputs the values to up to 127 Analog Output Modules.

• Analog Output Modules:

Converts the signal from the Receiver into a Resistance, Voltage or Current for sending to the controller.

• Repeater

Extends the range of the Transmitter up to 1,000 feet.

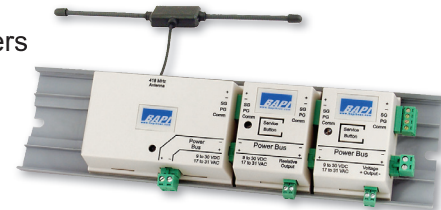

Receiver with two Analog Output Modules

Specifications

Supply Power: Two 3.6V Lithium batteries, 8 year battery life at 10 second transmit rate

Sensing Elements:

- Temp. - Semiconductor Band Gap, Proportional to Absolute Temperature, $\pm 0.54^{\circ}\text{F}$ ($\pm 0.3^{\circ}\text{C}$) @ 25°C
- Humidity - Capacitive Polymer, $\pm 2\%$ RH Accuracy, 10 to 90% @ 25°C

Transmitted Range: -40 to 185°F (-40 to 85°C) • 0 to 100% RH

Environmental Operation Range:

- Temp: 32 to 140°F (0 to 60°C)
- Humidity: 5% to 95% RH non-condensing

Material & Rating: ABS Plastic, UL94 V-0

Radio Frequency: 418 MHz

Transmitter Interval: ~10 seconds

Antenna: Built inside the enclosure

FCC Approval: FCC ID# T4F061213RSO

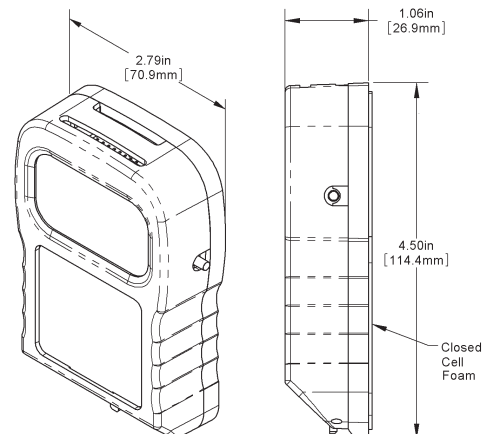

*Actual in-building transmission distances will vary depending upon building construction and other factors.

