

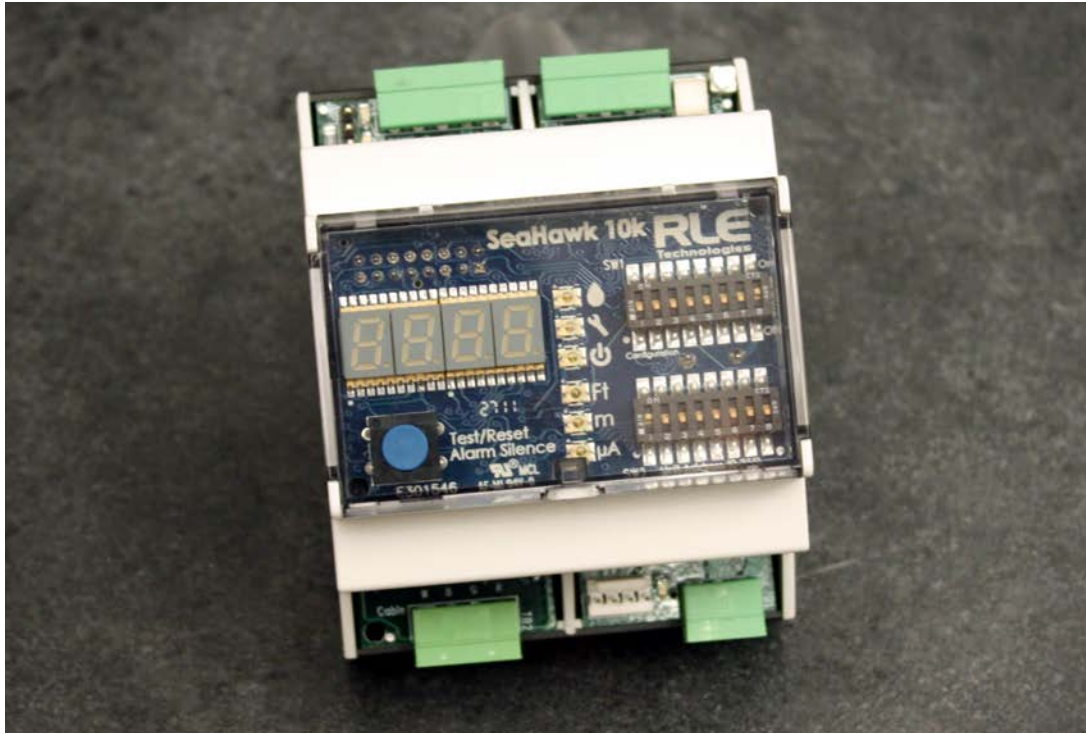

10K

User Guide

User Guide Version 05.22
Documented Using Firmware Version 3.2



Copyright and Trademark Notices

© Raymond & Lae Engineering, Inc. 2011. All rights reserved. RLE® is a registered trademark and SeaHawk™, Falcon™, and Raptor™ are trademarks of Raymond & Lae Engineering, Inc. The products sold by Raymond & Lae Engineering, Inc. are subject to the limited warranty, limited liability, and other terms and conditions of sale set forth at <http://www.rletech.com/>.

Revision History

Rev. No.	Date	Rev. No.	Date
1.0	April 2011	2.7	December 2016
1.1	May 2011	05.22	May 2022
2.0	August 2011		
2.1	December 2011		
2.2	November 2012		
2.3	August 2013		
2.4	August 2013		
2.5	September 2013		
2.5.a	July 2014		
2.6	September 2015		

Manufacturer's Notes

This product is manufactured by RLE Technologies, 104 Racquette Drive, Fort Collins, CO, 80524.

If this product is used in any manner other than that specified by the manufacturer, the protection provided by the equipment may be impaired.

Product Warranty

Warranty information for RLE products can be found at www.rletech.com.

Product Registration

Product registration helps RLE Technologies inform owners of:

- Product upgrades
- Firmware enhancements
- New products and technologies
- Special offers available only to registered users

Any information provided to RLE Technologies through the registration form will be regarded as confidential. RLE will not sell or distribute any of the information to third parties.

Technical Support

Before you install a 10K, refer to RLE Technologies' website, www.rletech.com, to ensure you are using the most recent version of all documentation.

Personal assistance is available Monday through Friday, from 8:00 a.m. to 5:00 p.m. Mountain Time.

A request for assistance may be sent to support@rletech.com.

Otherwise, please call us directly at: **800.518.1519**.

The following information is located on the bottom of each SeaHawk 10K unit. Please have this information available whenever a technical support call is placed:

Product Model Number	_____
Product Serial Number	_____
Product Manufacture Date	_____

The 10K is not a field-serviceable item and must be sent back to RLE Technologies for mechanical repair. Power must be disconnected (unplugged) from the 10K any time the unit is mechanically serviced. Physically unplug power from the unit any time you are making wiring connections to or from the 10K.

RLE cannot accept an item for repair without a Return Materials Authorization number, which must be provided by RLE.

Contents

1	Product Overview	11
	Description	11
	Operation	11
2	Installation and Configuration	13
	Prepare for Installation	13
	Physical Connection Overview	13
	Mount the SeaHawk 10K	14
	Establish Physical Connections	15
	TB1: Summary Relay (optional)	15
	TB2: Leader Cable	16
	TB3 and TB4: Input Power and EIA-485 Communications Port	17
	JMP - Termination Jumper	19
	Select Alarm Options	19
	Enable and Disable the Audible Alarm	19
	Set the Re-Alarm Interval	20
	Connect the SeaHawk Leak Detection Cable	20
	Connect Lengths of Sensing Cable	20
	Secure Sensing Cable to the Floor	21
	Apply Power to the SeaHawk 10K	22
	Test the System	22
3	Operation	25
	Front Panel Controls and Display	25
	Manage Alarms	27
4	Modbus Communication	29
	Modbus Implementation Basics	29
	Modes of Transmission	29
	Slave Address Field	29
	Function Field	29
	Data Field	30
	Error Check (Checksum) Field	30
	5-1.2 Exception Responses	30
	Packet Communications for the SeaHawk 10K	31
	Function 03: Read Output Registers	31
	Function 04: Read Input Registers	33
	RTU Framing	34
	Calibrate Cable Length via Modbus	35
5	Preventive Maintenance	37
6	Troubleshooting	39
A	Configuration Reference	41
	DIP Switches	41
	DIP SW1 Settings	42
	DIP SW2 Settings	43

Configure the SeaHawk 10K for Modbus Communications 43

Figures

1	Product Overview	11
2	Installation and Configuration	13
	Figure 2.1 SeaHawk 10K Physical Inputs	14
	Figure 2.2 Mount the SeaHawk 10K	14
	Figure 2.3 Relay Output (TB1) and Sensing Cable Connection (TB2)	15
	Figure 2.4 Power and Communications Connections (TB3 and TB4) and Termination Jumper (JMP)	15
	Figure 2.5 Relay Output Connection TB1	15
	Figure 2.6 General DIP Switch Settings	16
	Figure 2.7 DIP Switch 5, SW1 - Latched or Unlatched Alarms	16
	Figure 2.8 Cable Connection TB2	16
	Figure 2.9 DIP Switch 6, SW1 - Display Cable Length in Feet or Meters	17
	Figure 2.10 DIP Switch 7, SW1 - Ohms per Foot Resistance	17
	Figure 2.11 TB3 and TB4 Power Supply and Communications Connections	18
	Figure 2.12 DIP Switch Settings for Communications Baud Rate	18
	Figure 2.13 SW2 DIP Switch Settings for Communications Address	19
	Figure 2.14 DIP Switch 8, SW 1 - Audible Alarm Settings	19
	Figure 2.15 DIP Switch 4, SW1 - Re-Alarm Interval	20
	Figure 2.16 SeaHawk Sensing Cable	20
	Figure 2.17 Secure the Cable	21
3	Operation	25
	Figure 3.1 Front Panel Controls and Display	25
4	Modbus Communication	29
	Figure 4.1 DIP Switch Settings for Ohms/Foot	35
	Figure 4.2 Formula for Calculating Exact Cable Resistance	35
5	Preventive Maintenance	37
6	Troubleshooting	39
A	Configuration Reference	41
	Figure A.1 General Dip Switch Settings	41
	Figure A.2 SW1 Dip Switch Configuration Settings	42
	Figure A.3 SW2 DIP Switch Settings for Modbus Unit Address	43

Tables

1	Product Overview	11
2	Installation and Configuration	13
3	Operation	25
	Table 3.1 Front Panel Controls and Displays	26
4	Modbus Communication	29
	Table 4.1 Exception Codes	30
	Table 4.2 Read Output Register Packet Structure	31
	Table 4.3 Output Registers	31
	Table 4.4 Read Input Registers Packet Structure	33
	Table 4.5 Input Registers	33
	Table 4.6 Status Flags (Register 30001)	34
	Table 4.7 Response Sample	34
5	Preventive Maintenance	37
6	Troubleshooting	39
	Table 6.1 Troubleshooting	39
A	Configuration Reference	41

PRODUCT OVERVIEW

1.1. Description

As RLE's most cost effective distance-read leak detection solution, the SeaHawk 10K reports the presence of water and other liquids as detected by sensing cable.

Capable of accommodating up to 10,000 feet (3048m) of sensing cable, the SeaHawk 10K has an audible alarm and can communicate via Modbus. As a stand-alone solution, the SeaHawk 10K provides alarm notification and numeric distances on its front panel. Integration into a Modbus network allows the activity and status of one or multiple SeaHawk 10Ks to be managed from one central location.

1.2. Operation

Supervised System

The SeaHawk 10K is a *supervised system* – it continually monitors sensing cable and spot detectors for continuity – and produces alarms for the following conditions:

- ◆ Leak detection
- ◆ Cable break
- ◆ Cable contamination

Distance-Read Leak Detection

When the SeaHawk 10K's circuitry measures a current in excess of the user-defined leak threshold, the unit's microprocessor computes the distance to the leak. The SeaHawk 10K then annunciates the leak and communicates via Modbus to a master controller or a Modbus-equipped monitoring system. The summary relay sends notification to an alarm panel or monitoring system.

User Configuration and Communication

The SeaHawk 10K's front panel display – which includes a four-digit LED panel and six LED indicators – provides information about its status, including the following:

- ◆ Leak detected
- ◆ Cable fault detected
- ◆ Power status
- ◆ Configured unit of measure
- ◆ Leak detection cable's amperage value
- ◆ Distance to leak or contamination
- ◆ Length of installed leak detection cable
- ◆ Self-test results

The two blocks of DIP switches on the SeaHawk 10K's front panel are used for configuration. DIP SW1 configures parameters such as leak and contamination thresholds, latching alarms, and realarm time interval. DIP SW2 is used to set the Modbus address information for the unit.

The SeaHawk 10K also provides configuration capability and status information to a Modbus-equipped system via its EIA-485 port.

INSTALLATION AND CONFIGURATION

2.1. Prepare for Installation

To install the SeaHawk 10K, you'll need following supplies:

Included with the SeaHawk 10K

- ◆ 15 foot (4.57m) leader cable
- ◆ End-of-line terminator (EOL)

Available from RLE, sold separately

- ◆ Isolated power supply - 24VDC (RLE part PSWA-DC-24-ST) or 24VAC (RLE part WA-AC-24-ST)
- ◆ SeaHawk Sensing Cable, up to 10,000 feet (3048m)
- ◆ J-Clips

Available from other vendors

- ◆ Electrostatic discharge (ESD) protection

2.2. Physical Connection Overview

The SeaHawk 10K contains two circuit boards:

- ◆ The top circuit board houses operational controls and displays. SeaHawk 10K operational information is found in Chapter 3.
- ◆ The lower circuit board houses the connectors for:
 - AC/DC power
 - Earth ground
 - Relay output
 - Leak detection cable
 - Communications

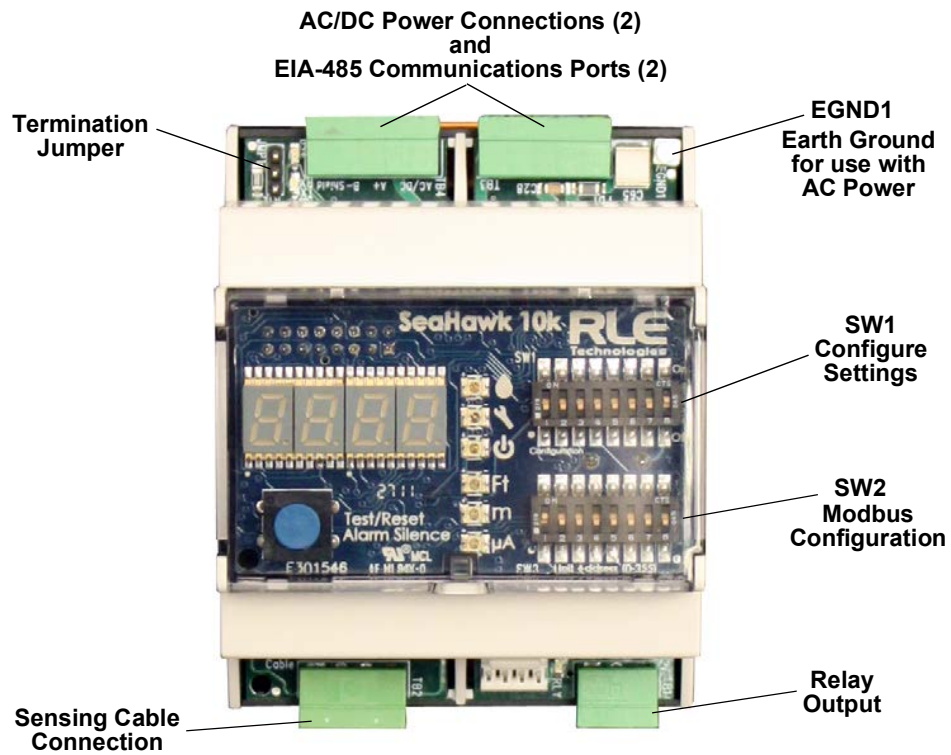

Figure 2.1 SeaHawk 10K Physical Inputs

2.3. Mount the SeaHawk 10K

The SeaHawk 10K can be mounted inside a panel or on a DIN rail. The device has two adjustable orange clips on the bottom. Push the clips out to expose two screw holes that allow the device to be mounted in a panel; push the clips in to mount it on a DIN rail.

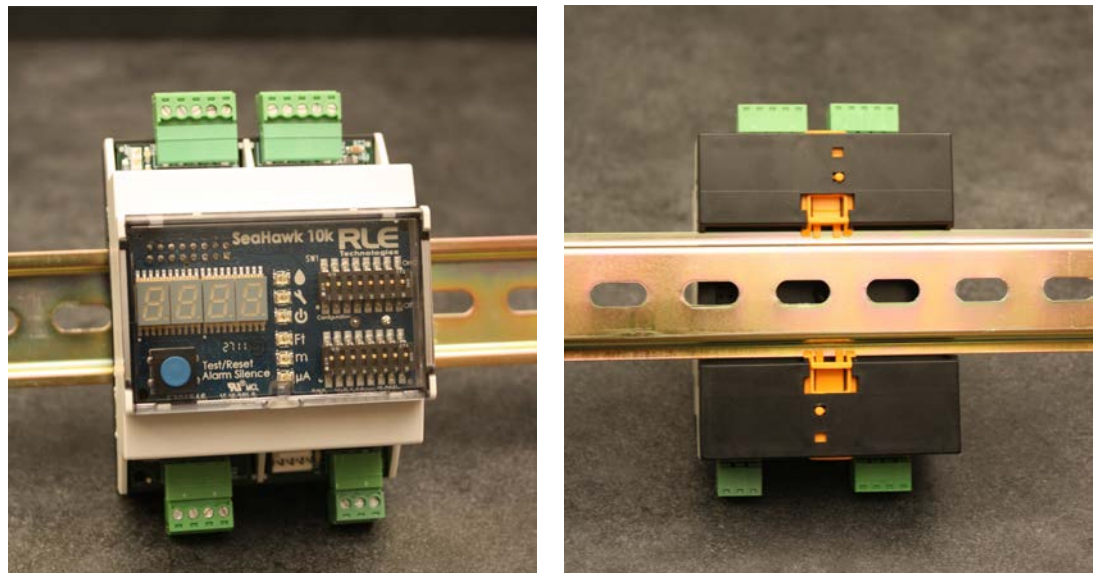

Figure 2.2 Mount the SeaHawk 10K

2.4. Establish Physical Connections

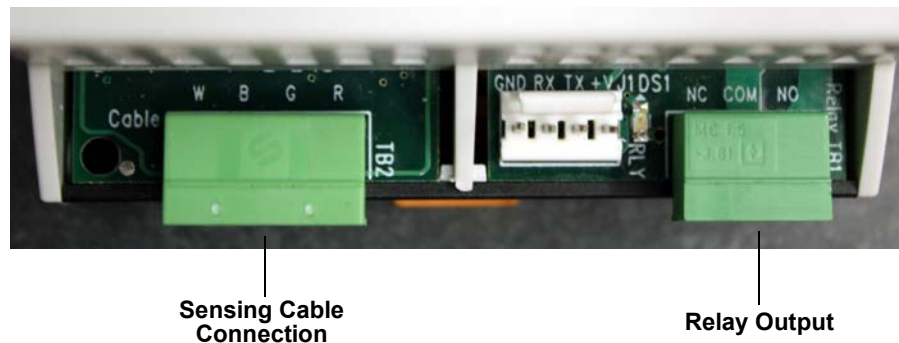

Figure 2.3 Relay Output (TB1) and Sensing Cable Connection (TB2)

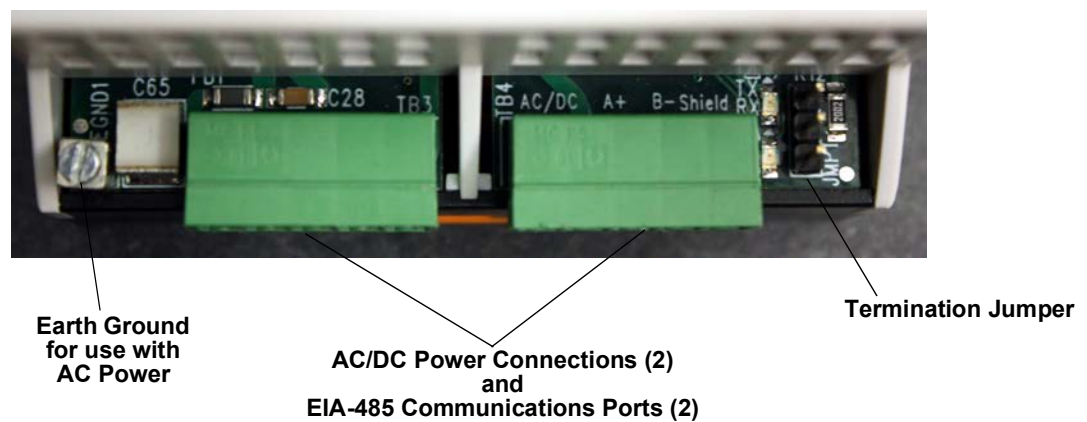

Figure 2.4 Power and Communications Connections (TB3 and TB4) and Termination Jumper (JMP)

2.4.1 TB1: Summary Relay (optional)

Terminal Block 1 is a Form C relay output. This relay enables alarm notification through a local or remote panel, master controller, or BMS whenever a leak, cable fault, or cable contamination is detected.

- 1 Insert the wires into the appropriate slots on TB1 to connect the relay output to the desired panel or controller.

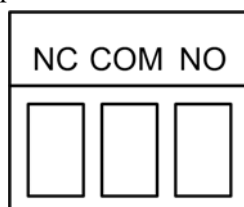

Figure 2.5 Relay Output Connection TB1

2 DIP switches are used to adjust settings on the SeaHawk 10K.

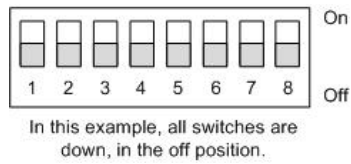

Figure 2.6 General DIP Switch Settings

Use DIP switch 5 on the SW1 DIP switch block to configure this relay as *latched* or *unlatched*.

- ◆ An *unlatched* alarm resets itself once a detected leak or cable problem has been resolved.
- ◆ A *latched* alarm must be manually reset, even if the detected leak or cable problem is no longer present.

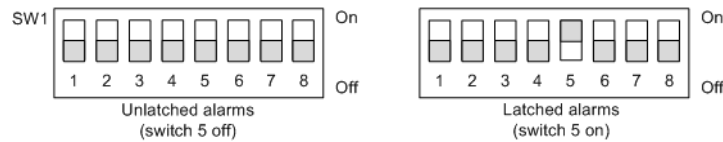

Figure 2.7 DIP Switch 5, SW1 - Latched or Unlatched Alarms

2.4.2 TB2: Leader Cable

1 A 15-foot (4.57m) section of non-sensing leader cable is supplied with each SeaHawk 10K. The leader cable connects sensing cable to the SeaHawk 10K, since sensing cable cannot connect directly to the unit. Insert its four stripped wires into the appropriate slots in TB2 – from left to right: white, black, green, and red.

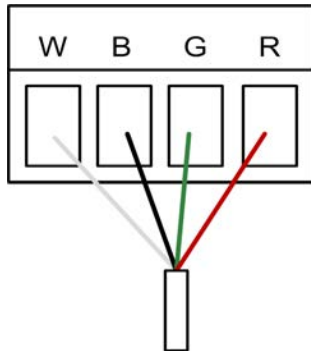

Figure 2.8 Cable Connection TB2

Note If the terminal connector is removed from the end of the cable, make sure the wires are in this same order, W - B - G - R, when the connector is reapplied.

- 2 Use DIP switch 6 in block SW1 to designate whether the distance on the display is shown in feet or meters:

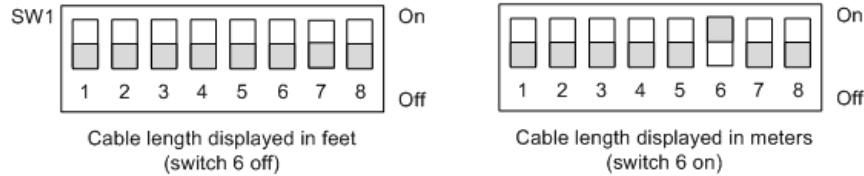

Figure 2.9 DIP Switch 6, SW1 - Display Cable Length in Feet or Meters

- 3 RLE's orange sensing cable has a resistance of 2.8 ohms per foot. Most other sensing cables have a resistance of 4.0 ohms per foot. If you have questions regarding the resistance of your cable, please reference the cable's data sheet. Set DIP switch 7 in block SW1 to the appropriate resistance-per-foot value.

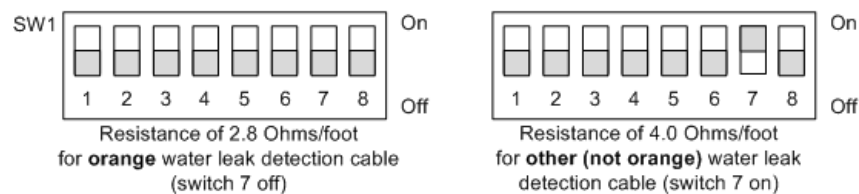

Figure 2.10 DIP Switch 7, SW1 - Ohms per Foot Resistance

2.4.3 TB3 and TB4: Input Power and EIA-485 Communications Port

The SeaHawk 10K requires an isolated power supply, either RLE part PSWA-DC-24-ST or WA-AC-24-ST. A power supply is not included with the SeaHawk 10K and should be purchased separately from RLE.



An isolated power supply must be provided for the SeaHawk 10K.

Do not connect 120/230 VAC to the unit, or damage will occur to the circuitry.

- 1 Run an isolated power supply to the location of the SeaHawk 10K, or use a DIN rail mountable power supply and mount it next to the SeaHawk 10K.
- 2 If you are installing just one SeaHawk 10K, use the two left-most pinouts on either TB3 or TB4 (marked AC/DC) to connect power to the SeaHawk 10K. Insert the positive and negative wires of the power supply into either of the pinouts; the SeaHawk 10K's circuitry will auto-correct.

If you are installing more than one SeaHawk 10K, use TB3 and TB4 to create a daisy-chained power connection.

- 3 If you are installing just one SeaHawk 10K and it will communicate via Modbus to a Modbus-enabled controller, use the three right-most pinouts on TB3 or TB4 to connect the SeaHawk 10K to an EIA-485 network.

If you are installing more than one SeaHawk 10K, use the appropriate pinouts of TB3 and TB4 to create a daisy-chained Modbus connection.

A grounded shield contact is provided for connection to shielded cable. If the shield contact is used, verify the power connector is properly grounded and there is no voltage potential between units on the Modbus network.

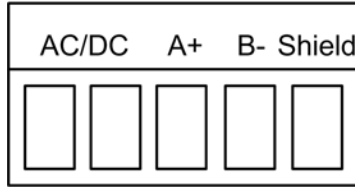

Figure 2.11 TB3 and TB4 Power Supply and Communications Connections

4 Set the baud rate for the EIA-485 port using DIP switches 1 and 2 on SW1:

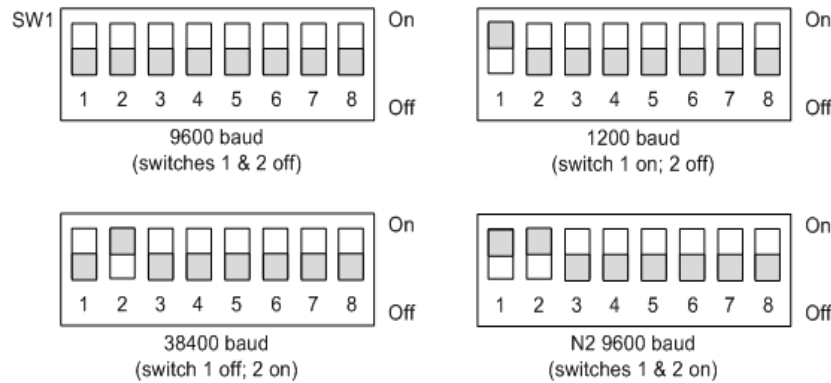

Figure 2.12 DIP Switch Settings for Communications Baud Rate

Note The EIA-485 port is set to 8 databits, no parity, and 1 stop bit (8, N, 1).

- 5 DIP SW2 is used to set the Modbus address. For further information regarding Modbus configuration, refer to [Section 4.1.](#), “[Modbus Implementation Basics](#)” on page 29.
- a If you are communicating via Modbus, you only need to set the Modbus address via SW2. The Modbus address should be a number between 1 and 254. Adjust the individual switches until their sum equals the Modbus address. The following illustration shows the values of the DIP switches on the SW2 block as well as two examples of how the DIP switches would be set for specific unit addresses.

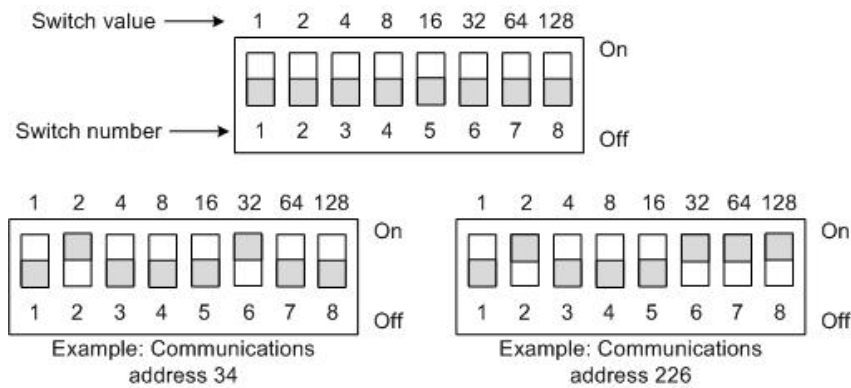

Figure 2.13 SW2 DIP Switch Settings for Communications Address

2.4.4 JMP - Termination Jumper

The termination jumper, labeled JMP, is located next to TB4. It is used to designate the end of the line unit in a daisy chain. The SeaHawk 10K ships with the jumper in the non-terminated position - over the two pins closest to the device enclosure. If your SeaHawk 10K is the only device in the application, or if it's not the last unit in the daisy chain, leave the jumper where it is. If your unit is the last device in a daisy chain, move the jumper so it is over the two pins nearest the end of the board.

2.5. Select Alarm Options

2.5.1 Enable and Disable the Audible Alarm

The audible alarm is disabled by default. To modify this setting, adjust switch 8 on DIP SW1:

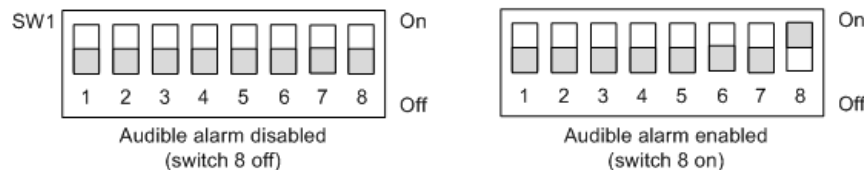

Figure 2.14 DIP Switch 8, SW 1 - Audible Alarm Settings

2.5.2 Set the Re-Alarm Interval

The SeaHawk 10K can be set to re-alarm – after a leak or cable fault has been detected, the alarm will be re-sent at a 4 hour interval until the alarm condition has been resolved. This re-alarm triggers both the audible alarm and the Modbus readout.

The re-alarm option is disabled by default. Activate the re-alarm setting with DIP switch 4 of SW1:

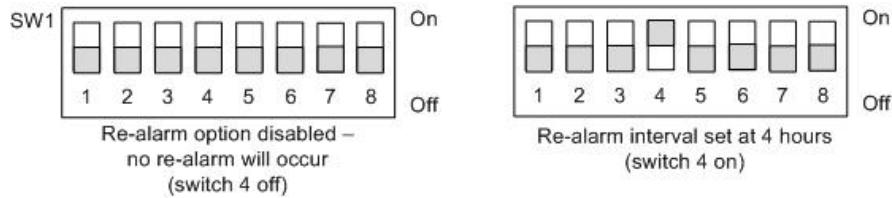

Figure 2.15 DIP Switch 4, SW1 - Re-Alarm Interval

2.6. Connect the SeaHawk Leak Detection Cable

IMPORTANT

To avoid faulty leak detection readings, connect a minimum length of 35 feet (10.7m) of sensing cable to the SeaHawk 10K.

The SeaHawk 10K is shipped with a 15-foot (4.57m) leader cable. This leader cable was connected to the SeaHawk 10K in Section 2.4.2 on page 16. The following directions help you connect sensing cable to the SeaHawk 10K.

2.6.1 Connect Lengths of Sensing Cable

- 1 Unscrew the end-of-line (EOL) terminator from the end of the leader cable.
- 2 Attach the first length of sensing cable to the leader cable. Insert the male pins into the female connector, and twist the collar on the female side of the connector to secure.

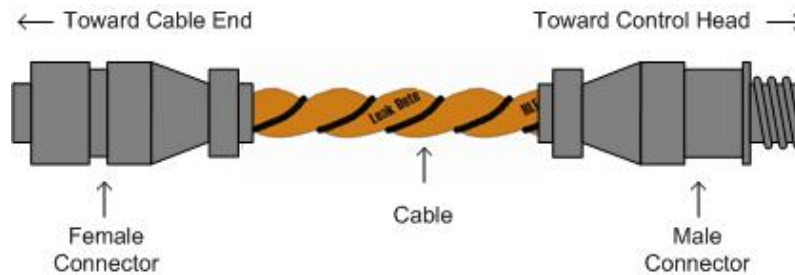

Figure 2.16 SeaHawk Sensing Cable

- 3 Route the sensing cable according to your cable layout diagram. Attach additional lengths of sensing cable as necessary.
- 4 Secure the EOL terminator to the unoccupied end of the last length of sensing cable.

Note If the EOL terminator is not present at the end of the cable run, a cable fault will register.

- 5 If you are using a reference map, compare it with the actual cable installation. Revise any discrepancies created through the physical installation of the cable.

2.6.2 Secure Sensing Cable to the Floor

Secure the sensing cable to the floor with either J-clips (RLE part #JC), or one of the other approved methods shown in [Figure 2.17](#). Available from RLE and designed specifically for use with sensing cable, J-clips are the manufacturer's recommended installation method.

- ◆ To avoid contaminating the cable, clean the entire floor as much as possible. Use isopropyl alcohol to clean the spots on the floor where J-clips will be placed.
- ◆ Place one J-clip every 5 to 6 feet (1.52 to 1.83m) along the length of the sensing cable and one at each turn of the cable. Use more J-clips if a tighter configuration is required.
- ◆ If the cable is installed over an obstruction, clip the cable on both sides, as close to the obstruction as possible.
- ◆ The J-clip's adhesive backing does not work well on porous concrete floors. RLE recommends using a drop of silicone or another nonconductive adhesive to help secure the J-clip to the floor.

IMPORTANT Do not install the cable directly in front of an air conditioner. Allow a minimum of 4 to 6 feet (1.22 to 1.83m) between the unit and the cable. If the cable is too close to the air conditioning unit's air stream, the moisture from the humidifier may cause false leak readings. If the cable must be installed in front of an air conditioning unit, place the J-clips 3 feet (0.91m) apart.

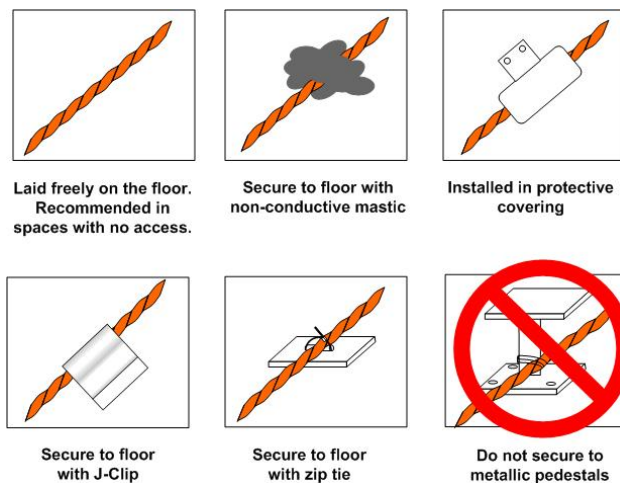

Figure 2.17 Secure the Cable

2.7. Apply Power to the SeaHawk 10K



WARNING

An isolated power supply must be provided for the SeaHawk 10K. In addition, a dedicated circuit breaker must be provided within close proximity to the SeaHawk 10K and be clearly marked as the disconnecting device for the SeaHawk 10K leak detection controller.

Do not connect 120/230 VAC to the unit, or damage will occur to the circuitry.

1 An isolated power supply was run and power was connected to the SeaHawk 10K in [Section 2.4.3 on page 17](#).

2 Ensure all connections are correct and all screw terminals are secure.

Note For AC power connections, wire EGND1 to Earth ground.

3 Apply power to the SeaHawk 10K. The device will begin to boot.

4 Wait approximately one minute for the SeaHawk 10K to start up. Under normal operating conditions, the power LED glows green and the LED display reads **SH10**.

5 No alarm should be present. If an alarm is present, consult Chapter 6 for troubleshooting information.

6 Press the Test/Reset button **once** to verify the amperage reading. For new leak detection cable, the amperage will be either 0 or 1 μA . If the current is higher than 0 or 1 μA , contamination may have been introduced during installation. Clean the floor, and then use isopropyl alcohol to clean the cable. If the sensing cable is not new, the reading may be higher. RLE recommends cleaning the cable if the amperage reading is 15 μA or higher.

7 Press the Test/Reset button **twice** to verify the length of installed sensing cable. If the length displayed is different from the actual length installed, consult [Chapter 6](#) for troubleshooting information.

2.8. Test the System

Note If the SeaHawk 10K is already connected to a BMS or NMS, notify monitoring personnel before you begin testing the system.

1 To verify the SeaHawk 10K's accuracy, test three points within the length of sensing cable - one at the beginning, one in the middle of the length, and another near the end of the length of cable.

2 There are a variety of ways to simulate a leak.

- ◆ Pour a small puddle of water on the cable while it rests on the floor.
- ◆ Dunk the cable in a cup of water.

- ◆ Wet a paper towel or rag and wrap it loosely around the cable. This is popular if the cable is used in pipe applications. Be careful to wrap the wet cloth loosely around the cable. Do not put pressure on the cable.

IMPORTANT To avoid inaccurate readings, do not grip the cable with your hand.

- 3 Verify that the SeaHawk 10K reports the leaks within approximately two feet of their actual physical location.
- 4 Remove all simulated leak sources and return the system to its normal operating state.

OPERATION

3.1. Front Panel Controls and Display

The front panel of the SeaHawk 10K contains a 4-character LED and series of colored LEDs that are used together to convey device status and information regarding detected leaks and cable faults. A blue button is used to cycle the 4-character LED, silence the audible alarm, and reset the alarm.

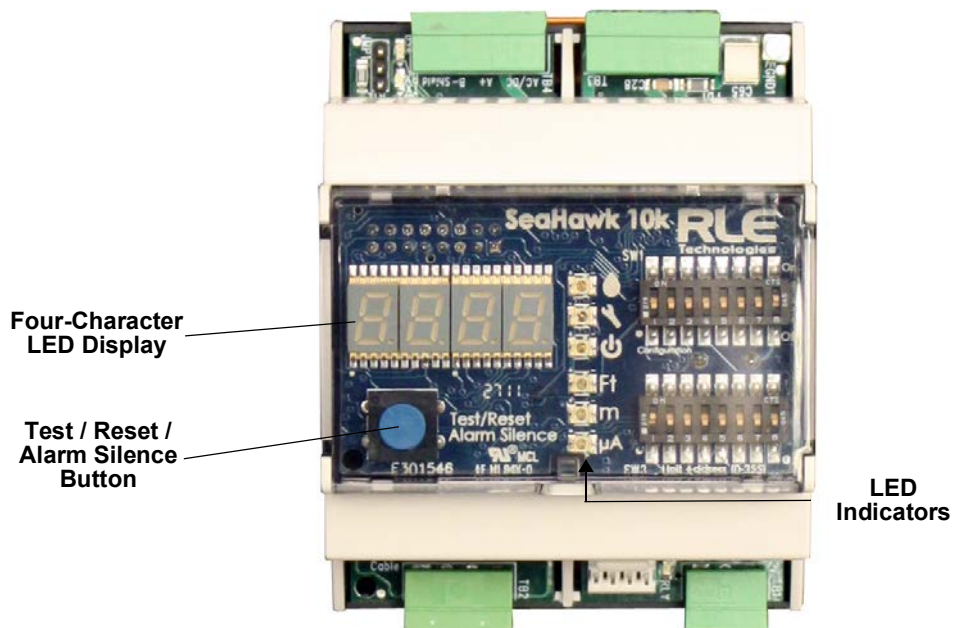

Figure 3.1 Front Panel Controls and Display



Front Panel Indicator	Symbol	Description
4-character LED	SH10 675(e.g.) cbr	<ul style="list-style-type: none"> System is running in its normal operating state. A leak, fault, or contamination has been detected. The numerical distance to the leak displays on the LED. A green LED lights next to the appropriate distance measurement, and either the LED next to the water drop glows red to indicate a leak, or the LED next to the wrench glows yellow to indicate cable contamination. If the distance is measured in meters, a tenths place decimal value will appear in measurements from 0.0 - 999.9. All meter values over 1000 will display as whole meter measurements. A cable break or fault has been detected. A yellow LED flashes next to the wrench symbol.
LED	   Ft m μ A	<ul style="list-style-type: none"> Red LED - leak is detected - distance is displayed on 4-character LED Yellow LED - Cable fault - 4-character LED displays cbr Yellow LED - Cable contamination - 4-character LED displays the distance to the contamination Green LED - Power on Green LED - Measurements are made in feet Green LED - Measurements are made in meters Green LED - Microamps of current on cable - amperage is displayed on 4-character LED
Test/Reset/Alarm Silence Button	Blue Push Button	<p>In normal operating conditions, the button functions include:</p> <ul style="list-style-type: none"> Press once: Displays cable current in ohms/foot and the green LED lights next to the microamp symbol Press twice: Displays the length of installed cable components and the green LED lights next to the appropriate Ft or m symbol Press three times: Return to the default display (SH10) Press and hold: Self-test is initiated and the character display reads ca1 8060, which indicates the value of the test resistor. <p>If an alarm sounds, briefly press the button to turn off the audible alarm. The Status LED remains red, and the 4-character LED continues to show the alarm condition.</p> <p>In an alarm condition, whether the audible alarm is sounding or not, press and hold this button for 3 seconds to clear the alarm.</p>

Table 3.1 Front Panel Controls and Displays

3.2. Manage Alarms

General Guidelines

- 1 If the audible alarm sounds, briefly press the Test/Reset button to silence it.
- 2 Look at the display, or read the appropriate Modbus register, to determine the type of alarm and the distance to the leak, contamination, or cable break.
- 3 If you have a leak detection reference map, cross-reference the distance with the map.
- 4 Fix the problem (fix the leak, then dry the area and the section of cable involved in the leak; replace broken cable; clean contaminated cable).

Contamination Alarm Guidelines

If the cable is in a contamination alarm state, check the following:

- ◆ Verify that the cable is at least 4 feet (1.22m) away from any air conditioning unit.
- ◆ If there is dirt, grit, or grime on the cable, clean the cable with isopropyl alcohol and a clean rag.
- ◆ If the cable is in a high traffic area, move it or install a cable protector over it.

MODBUS COMMUNICATION

4.1. Modbus Implementation Basics

The SeaHawk 10K uses its EIA-485 port to communicate via Modbus. The SeaHawk 10K is configured to act as a slave device on a common network and is a slave only device – it will never initiate a communications sequence.

4.1.1 Modes of Transmission

The SeaHawk 10K supports the Modbus RTU mode of transmission, with 8 data bits, no parity and one stop bit. Every Modbus packet consists of four fields:

- ◆ Slave Address Field
- ◆ Function Field
- ◆ Data Field
- ◆ Error Check Field (Checksum)

4.1.1.1 Slave Address Field

The slave address field is one byte in length and identifies the slave device involved in the transaction. The valid Modbus slave address range is between 1 and 254. The Modbus address was set in [Chapter 2, “TB3 and TB4: Input Power and EIA-485 Communications Port” on page 17](#). Refer to [Figure 2.13, “SW2 DIP Switch Settings for Communications Address” on page 19](#) for more specific information.

4.1.1.2 Function Field

The function field is one byte in length and tells the SeaHawk 10K which function to perform. Functions are 03 (Read 4xxxx output registers) and 04 (Read 3xxxx input registers) are supported by the SeaHawk 10K.

4.1.1.3 Data Field

The length of the data field varies depending on the function. The data fields for the SeaHawk 10K are 16-bit registers, transmitted high order byte first (big-endian).

4.1.1.4 Error Check (Checksum) Field

The checksum field lets the receiving device determine if the packet has transmission errors. The SeaHawk 10K RTU mode uses a 16-bit cyclic redundancy check (CRC-16).

4.1.1.5 5-1.2 Exception Responses

If a Modbus master sends an invalid command to the SeaHawk 10K or attempts to read an invalid register, an exception response is generated. The response packet will have the high order bit of the function code set to one. The data field of the exception response contains the exception error code.

Code	Name	Description
01	Illegal Function	The function code is not supported
02	Illegal Data Address	Attempt to access an invalid address
03	Illegal Data Value	Attempt to set a variable to an invalid value

Table 4.1 [Exception Codes](#)

4.2. Packet Communications for the SeaHawk 10K

4.2.1 Function 03: Read Output Registers

To read the SeaHawk 10K parameter values, the master must send a Read Output Registers request packet.

The Read Output Registers request packet specifies a start register and the number of registers to read. The start register is numbered from zero (40001 = zero, 40002 = one, etc.).

Read Registers Request Packet	Read Registers Response Packet
Slave Address (1 byte)	Slave Address (1 byte)
03 (Function code) (1 byte)	03 (Function code) (1 byte)
Start Register (2 bytes)	Byte count (1 byte)
# of registers to read (2 bytes)	First register (2 bytes)
CRC Checksum (2 bytes)	Second register (2 bytes)
	...
	Cry Checksum (2 bytes)

Table 4.2 Read Output Register Packet Structure

Register	Name	Description	Units	Range
40001	Leak Threshold	Trip point for leak alarm	25-175 uAmps Default: 120 uAmps	0-65535
40002	Contamination Threshold	Trip point for contamination alarm	25-175 uAmps Default: 50 uAmps	0-65535
40003	Re-alarm Interval (read-only)	Amount of time that passes before unit resends alarm notification Note: Set with DIP SW1; this register is read-only.	0 (Disabled) or 4 hours Default: 0 (Disabled)	0-65535
40004	Latched Alarms (read-only)	Latched alarm requires SeaHawk 10K to be reset once alarm is cleared. Note: Set with DIP SW1; this register is read-only.	0 = Disabled 1 = Enabled Default: Disabled	0-65535
40005	Silence Audible Alarm	Indicates whether or not the audible alarm sounds when the SeaHawk 10K goes into alarm state	0 = Disabled 1 = Enabled Default: Disabled	0-65535

Table 4.3 Output Registers

Register	Name	Description	Units	Range
40006	Reset Alarm	Resets the SeaHawk 10K after an alarm state. Alternatively, press and hold the front panel's Test/Reset button for 3 seconds.	0 = Disabled (do not reset alarm) 1 = Enabled (reset alarm) Default: 0 (Disabled)	0-65535
40007	Sample Size	Number of samples taken to calculate the leak location	0 = Set to default value 4 = Minimum 25 = Maximum Default: 12	0-65535
40008	Resistance per Foot	Milliohms of resistance of installed leak detection cable. This value is set here and can also be read through register 30008.	2000 – 3500 Milliohms/foot* or 3500 – 4240 Milliohms/foot* *to convert this value to Ohms/foot, divide the number by 1000	0-65535
40009	AC Rejection Frequency	Used by ADC to reject AC powerline frequencies. Needed only if the SeaHawk10K is running on 24VAC power.	0 = 60Hz 1 = 50Hz Default: 1 (50Hz)	0-65535
40010	<i>Spare</i>	Not used.		0-65535
40011	<i>Spare</i>	Not used.		0-65535
40012	<i>Spare</i>	Not used.		0-65535
40013	<i>Spare</i>	Not used.		0-65535
40014	<i>Spare</i>	Not used.		0-65535
40015	<i>Spare</i>	Not used.		0-65535
40016	Leak Alarm Delay	Amount of time that passes between leak detection and alarm notification.	5 – 990 seconds Default: 10 seconds	0-65535
40017	Contamination Alarm Delay	Amount of time that passes between cable contamination detection and alarm notification.	5 – 990 seconds Default: 120 seconds	0-65535

Table 4.3 Output Registers

4.2.2 Function 04: Read Input Registers

To read the SeaHawk 10K input values, the master must send a Read Input Registers request packet.

The Read Input Registers request packet specifies a start register and the number of registers to read. The start register is numbered from zero (30001 = zero, 30002 = one, etc).

Read Registers Request Packet	Read Registers Response Packet
Slave Address (1 byte)	Slave Address (1 byte)
04 (Function code) (1 byte)	04 (Function code) (1 byte)
Start Register (2 bytes)	Byte count (1 byte)
# of registers to read (2 bytes)	First register (2 bytes)
CRC Checksum (2 bytes)	Second register (2 bytes)
	...
	CRC Checksum (2 bytes)

Table 4.4 Read Input Registers Packet Structure

Register	Name	Description	Units	Range
30001	Status	Bit level status	None	0-65535
30002	Leak Distance	Location of leak	Ft/Decimeters	0-65535
30003	Units	Unit of measure	0=Meters 1=Feet	0-65535
30004	Leak Current	Leakage current on cable	μA	0-65535
30005	Cable Length	Installed cable length	Feet/Decimeters	0-65535
30006	Leg1 Res	Resistance of cable A read-only value, this value is calculated directly from the installed leak detection cable.	Ohms	0-65535
30007	Leg2 Res	Resistance of cable A read-only value, this value is calculated directly from the installed leak detection cable.	Ohms	0-65535
30008	Res/Ft	Resistance of cable per foot This value is set through register 40008	Milliohms* *to convert this value to Ohms, divide the number by 1000	0-65535

Table 4.5 Input Registers

Register	Name	Description	Units	Range
30009	Version	Firmware version	x.x.x (If the register reads 301, the firmware version is 3.0.1)	0-65535
38001	Leak Distance	Leak distance in meters - float point - displays with a tenths place decimal value. This register must be viewed and displayed as float inverse.	Meters	0.0-9999.9
38003	Cable Length	Cable length in meters - float point - displays with a tenths place decimal value. This register must be viewed and displayed as float inverse.	Meters	0.0-9999.9

Table 4.5 Input Registers (continued)

Bit	Description
00	1 = Leak detected
01	1 = Cable break detected
02	1 = Contamination detected
03	1 = Summary alarm
04-15	Spare

Table 4.6 Status Flags (Register 30001)

4.3. RTU Framing

The example below shows a typical Query/Response from an SeaHawk 10K module.

Slave Address	Function Code	Count Bytes of Data	Register Data Msb	Register Data Lsb	Register Data Msb	Register Data Lsb	Register Data Msb	Register Data Lsb	CRC 16 "Lsb"	CRC 126 "Msb"
02	04	06	00	00	00	00	00	01	B5	A3

Table 4.7 Response Sample

Slave address 2 responds to Function Code 4 with six bytes of hexadecimal data and ends with CRC16 checksum.

Register Values:

- 40001 = 0000 (hex)
- 40002 = 0000 (hex)
- 40003 = 0001 (hex)

4.4. Calibrate Cable Length via Modbus

The length of sensing cable connected to the SeaHawk 10K can be calibrated through a Modbus-enabled system. This helps fine-tune a distance-read leak detection system. If no alarms are present, follow these steps to calibrate and test the system:

- 1 Set the SW1 DIP switches for the correct cable resistance per foot, as follows:

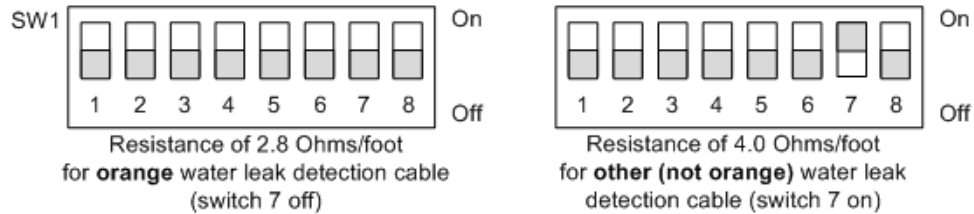

Figure 4.1 DIP Switch Settings for Ohms/Foot

- 2 Press the Test/Reset button on the controller once to verify the cable's amperage reading. Calibration cannot be performed if the current is above 15 μA .

Different sensing cables are cleaned in different ways. The following cleaning instructions apply to RLE's orange sensing cable ONLY! If you have questions regarding the care and maintenance of your sensing cable, please consult the cable's data sheet or contact the manufacturer.

If the cable is new and the current is higher than 1 μA , clean the cable. Isopropyl alcohol removes any contamination that might have been introduced to the cable during installation.

If the cable is older and the amperage reading is above 15 μA , clean the cable. A mild dish detergent solution removes most dirt. Isopropyl alcohol is also an effective cable cleaner.

- 3 Sensing cable has a resistance - for example, RLE's orange cable has a resistance of 2.8 ohms per foot. A system's actual resistance will rarely be exactly 2.8 ohms per foot, but it will be close - each individual cable or system will vary a very small bit from that 2.8 ohms per foot value. If you know the exact resistance of your cable, you can fine-tune your system for a more precise distance reading. The formula for calculating this value - and more specific directions for using the formula - are as follows:

$$\text{Resistance per foot in milliohms/foot (Modbus register 40008)} = \frac{\text{Leg2 Resistance (Modbus register 30007)}}{\text{Total Feet of Cable Installed on the System}} \times 1000$$

Figure 4.2 Formula for Calculating Exact Cable Resistance

- 4 Read the Leg 1 and Leg 2 Resistance values in Modbus registers 30006 and 30007. Ensure that the readings are similar - within 2% of each other. This helps rule out any major cable problems before calibration begins. Record the resistance reading from Leg 2, Modbus register 30007.

- 5 Add up all the lengths of sensing cable and any other equipment in the system that simulates a length of cable. Record this value. Keep in mind:
 - ◆ Each weighted cable connector (WCCS-50) simulates 50 feet (15.24m) of cable.
 - ◆ Each SD-Z simulates 50 feet (15.24m) of cable.
 - ◆ Each X-Connector (XCON) simulates 150 feet (45.72m) of cable.
- 6 Divide the Leg 2 resistance by the total length of cable. This value is the resistance of the cable installed on your system in ohms per foot. This ohms per foot value is for your reference only (the ohms per foot value will have a decimal point in it, and you cannot write a number with a decimal point to register 40008). Record this value.

Multiply the value in ohms per foot by 1000. This will give you the value in milliohms per foot. This milliohms per foot value is your end result, and the number you will write to Modbus register 40008. Record this value.

- 7 Access your Modbus-enabled system. Write the milliohms per foot resistance value to the SeaHawk 10K's Modbus register 40008.

Example:

$$\begin{array}{rcl}
 & & \text{Leg2 Resistance (Modbus register 30007)} \\
 & & \mathbf{2091} \\
 \mathbf{2788} & = & \frac{\mathbf{2091}}{\mathbf{750}} \times 1000 \\
 \text{Resistance per foot} & & \text{Total Feet of Cable Installed on the System} \\
 \text{in milliohms/foot} & & \\
 \text{(Modbus register 40008)} & &
 \end{array}$$

- ◆ The Leg 2 resistance reading on the system is 2091 ohms.
- ◆ The system has 400 feet of sensing cable,
 - 1 X-Connector - which simulates 150 feet of sensing cable,
 - 4 SD-Zs which simulate 50 feet of cable each, for a total of 200 feet of sensing cable
 System-wide, there are 750 feet of actual and simulated cable.
- ◆ Divide 2091 ohms by 750 feet of cable. You get a resistance of 2.788 ohms per foot.
- ◆ Multiply 2.789 ohms per foot by 1000 to get 2788 milliohms per foot.
- ◆ Access Modbus register 40008 and record the new milliohms per foot value, 2788.

PREVENTIVE MAINTENANCE

Follow these steps monthly to test the SeaHawk 10K and ensure that the device is functioning properly. If your SeaHawk 10K is hooked into a BMS or NMS, notify monitoring personnel before you begin to test the system.

- 1 Place water on the cable - either dip the cable into a cup filled with water, wrap the cable with a wet cloth, or pour a puddle of water onto the cable.
- 2 Verify the “leak detected” alarm on the control panel.
- 3 Compare the distance reading on the SeaHawk 10K to a reference map (if available) to ensure the SeaHawk 10K displays the correct leak location. See [Chapter 4 on page 35](#) for more information about calibrating the leak detection cable.
- 4 Dry the cable and verify the SeaHawk 10K returns to normal.
- 5 Remove the End-of-Line terminator (EOL).
- 6 Confirm the “cable break” (cbr) alarm on the SeaHawk 10K.
- 7 Reinstall the EOL.
- 8 Verify the SeaHawk 10K returns to normal.
- 9 Monitor the cable current monthly to ensure the cable is not being contaminated. The SeaHawk 10K will alarm if the contamination is excessive.
- 10 Monitor the cable current. If the cable current is greater than 15 μ A, troubleshoot the cables to determine which cable is contaminated. The contaminated cable should be removed, cleaned, and retested.

TROUBLESHOOTING

Table 6.1 Troubleshooting

Problem	Action
Control panel will not power up	<ol style="list-style-type: none"> <li data-bbox="451 919 1427 1066">1 Check with a DVOM (multi-meter) for AC or DC input power on the lower left hand terminal block on the SeaHawk 10K. If no voltage is present at the terminal block, check the power supply and circuit breaker that power the SeaHawk 10K. If voltage is present but no LEDs are illuminated, go to step 2. <li data-bbox="451 1066 1427 1115">2 Contact RLE Technologies for further troubleshooting and evaluation.
Cable Break Alarm	<ol style="list-style-type: none"> <li data-bbox="451 1115 1427 1192">1 Verify the leader cable from the sensing cable run is plugged into TB2, the terminal block marked "Cable." <li data-bbox="451 1192 1427 1270">2 Verify the End-of-Line terminator (EOL) is installed on the end of the orange sensing cable run. <li data-bbox="451 1270 1427 1528">3 A section of sensing cable may be damaged or faulty. To isolate a section of damaged sensing cable, remove the EOL terminator from the end of the cable run and install it onto the end of the leader cable coming from the control panel. If the condition clears, there is a damaged/faulty section of sensing cable. Start moving the EOL terminator to the end of each section of sensing cable to isolate the faulty section. If you do not find a faulty section of cable and the cable break alarm does not clear, go to step 4. <li data-bbox="451 1528 1427 1791">4 If the sensing cable is all functional, the leader cable may be damaged or faulty. To test the leader cable, power down (shut off) the control panel. Remove the terminal block marked "Cable" from the unit. Remove the four leader cable wires going into the four position terminal block. Install a jumper wire between pins 1 and 2 and another jumper wire between pins 3 and 4. Reinstall the terminal block back into TB2 and reapply power. If the cable break condition clears, there is a problem with the leader cable. If the condition does not clear, contact RLE Technologies for further support.

Table 6.1 Troubleshooting (continued)

Problem	Action
Control panel does not calculate the proper length of cable	<ol style="list-style-type: none"> <li data-bbox="462 283 1437 346">1 Verify the leader cable wires are wired into TB2, the terminal block marked "Cable," in the correct order - from left to right, white - black - green - red. <li data-bbox="462 367 1437 499">2 Calibrate the cable. To do this, adjust the resistance per foot (Configuration menu via the Web Interface). The control panel is pre-calibrated from the factory. The overall footage should be within 5% of actual installed length. If the condition does not change, please contact RLE Technologies
Control panel does not calculate the proper leak distance	<ol style="list-style-type: none"> <li data-bbox="462 508 1437 682">1 Check to see if multiple leaks are present on the cable. The first leak should be read and latched by the system; however, if the system is updated, or if two or more simultaneous leaks occur within 30 seconds of the initial leak, the system may display an average distance (sum of the distances to all the leaks ÷ the total number of leaks). If no water is present, continue to step 2. <li data-bbox="462 693 1437 1171">2 A section of the sensing cable may be faulty. To determine if this is the case: <ol style="list-style-type: none"> <li data-bbox="495 745 1437 808">a Power down the control panel and remove the End-of-Line terminator (EOL) from the end of the sensing cable. <li data-bbox="495 829 1437 913">b Find the junction between the first and second sections of sensing cable. Separate the two sections and install the EOL terminator at the end of the first section of sensing cable. <li data-bbox="495 934 1437 1060">c Turn power back on at the control panel. Allow the control panel to run for five to ten minutes. Apply a damp cloth, rag or paper towel to the end of the first section of orange sensing cable. If the leak is calculated correctly, remove the EOL terminator; reconnect the sensing cable and move down to the next section of cable. <li data-bbox="495 1081 1437 1171">d Repeat this process until a faulty reading is obtained. If the reading is off at the first section of cable, the SeaHawk 10K may be miscalculating distance. Please contact RLE Technologies for support.
Persistent Cable Contamination Alarm	<ol style="list-style-type: none"> <li data-bbox="462 1180 1437 1312">1 Unless an obvious contaminate can be found, to clear a contamination alarm the cable must be removed from its installation and cleaned. Usually the cable can be cleaned by pulling it through a clean damp rag. You can also wipe the cable with isopropyl alcohol. <li data-bbox="462 1333 1437 1501">2 If the cable is contaminated by oil, glycol or chemicals, the cable can be washed. Remove the cable from its installation, and submerge in a solution of one capful mild dish washing detergent to two gallons lukewarm water (<105°F). Agitate the cable in the solution, rinse with clear lukewarm water and wipe dry with a clean towel. <li data-bbox="462 1522 1437 1579">3 Connect the cable to the SeaHawk 10K and test it to make sure the contaminants have been removed before reinstalling the cable under the floor.

Note Contamination and/or physical damage to the cable is not covered under warranty. For all other troubleshooting concerns and questions regarding this product, contact RLE Technologies.



CONFIGURATION REFERENCE

This chapter provides a complete listing of all possible configuration and address settings that can be made using the DIP switches in blocks SW1 and SW2.

The configuration of a stand-alone SeaHawk 10K can be performed using the DIP switches on the front panel. If the SeaHawk 10K will be connected to a Modbus-equipped monitoring system, some of the configuration can be performed using the registers. Chapter 2 describes how to install and configure the SeaHawk 10K and refers to specific DIP switch settings where appropriate. Information about Modbus communications can be found in Chapter 4.

A.1. DIP Switches

The SeaHawk 10K contains two blocks of DIP switches.

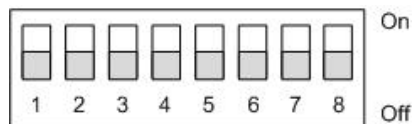

In this example, all switches are down, in the off position.

Figure A.1 General Dip Switch Settings

A.2. DIP SW1 Settings

DIP switch 1 manipulates basic configuration settings on the SeaHawk 10K. Dip switch 3 in SW1 is unused and should remain in the OFF position.

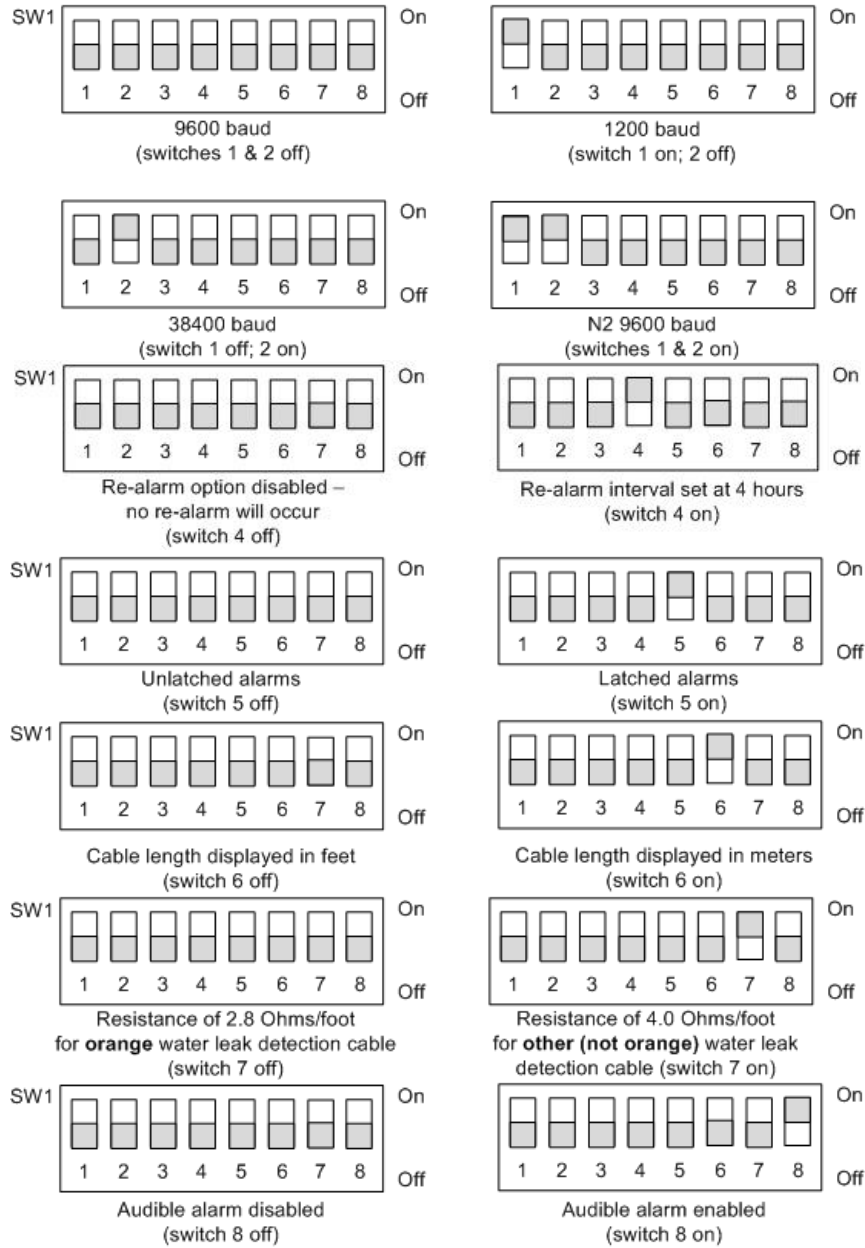

Figure A.2 SW1 Dip Switch Configuration Settings

A.3. DIP SW2 Settings

DIP switch 2 is used to set the address of the Modbus device. First, use switches 1 and 2 on SW1 to set the communication baud rate. Then, use the switches on DIP SW2 as follows for the communications you plan to employ.

A.3.1 Configure the SeaHawk 10K for Modbus Communications

The Modbus address should be a number between 1 and 254. Adjust the individual switches until their sum equals the Modbus address. Figure A.3 shows the values of the DIP switches on the SW2 block as well as two examples of how the DIP switches would be set for specific unit addresses.

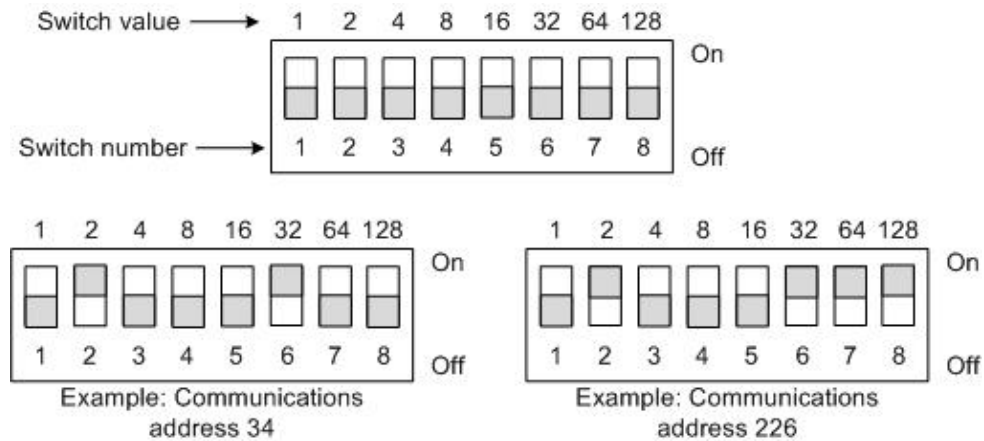

Figure A.3 SW2 DIP Switch Settings for Modbus Unit Address

