



Relay Replicator  
10x20 and 20x40



Relay Splitter  
and Alarm Annunciator  
(RA1x2)



# Raptor Relay Replicators

The Raptor Relay Replicator (RR) converts digital dry contact inputs into multiple isolated digital dry contact outputs. This function allows digital dry contact alarm signals to be connected to multiple alarm monitoring systems. The Relay Replicator interfaces with any equipment, device, monitoring system, or panel that accepts digital dry contact inputs.

Many types of equipment and devices use dry contact outputs to send alarm signals to remote panels, remote monitoring systems, or building management systems (BMSs). These outputs are designed to be wired to one remote system, and users often require a dry contact output to be wired to two or more systems. Wiring a single output relay contact to two remote panels can cause damage to the remote panels' components. To solve this problem, the Relay Replicator splits a signal into two electrically isolated outputs before it is sent to multiple remote panels.

The Relay Replicator Series includes 1x2 (RA1x2; see separate datasheet for specifications), 10x20 (RR10x20), and 20x40 (RR20x40) configurations. Contact inputs can be wired to multiple RR input channels to provide additional sets of isolated relay outputs.

## Features

- Duplicates digital dry contact inputs
- Safely isolates digital dry contact inputs
- Up to 20 inputs and 40 outputs
- Custom configurations available

## Benefits

- Allows simultaneous alarms to be received in multiple locations
- Replicates signals safely without damaging remote panels
- Enables building management system integration
- Meets unique requirements

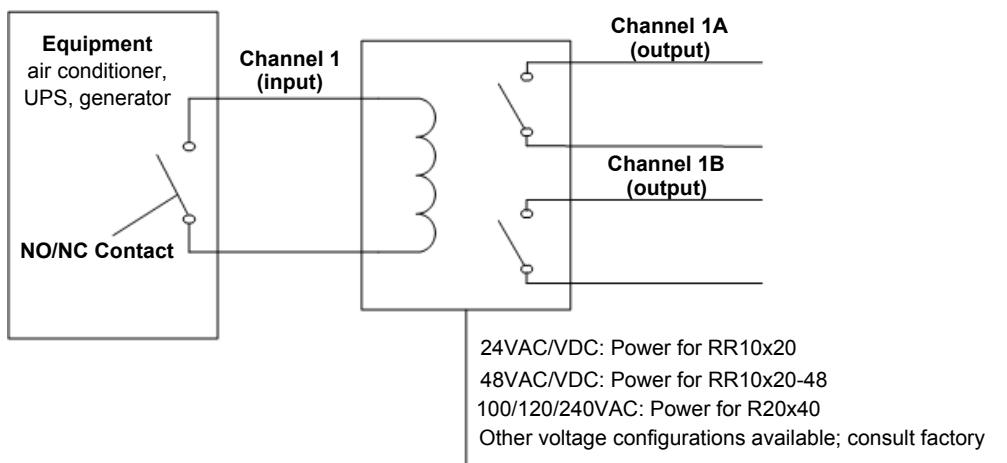

Schematic illustrating the use and placement of the Relay Replicator

# Integration

## Illustration of Application

**Scenario:** A generator has ten dry contact outputs. A facility manager wants to wire these dry contact outputs to a Falcon FMS unit and to the Building Management System (BMS).

**Solution:** A 10x20 Relay Replicator suits this application.

The ten dry contact outputs are wired from the generator to the RR10x20. The RR10x20 provides two electrically isolated digital dry contact outputs for each dry contact input from the generator. Ten outputs are wired to the Falcon FMS unit and ten to the BMS.

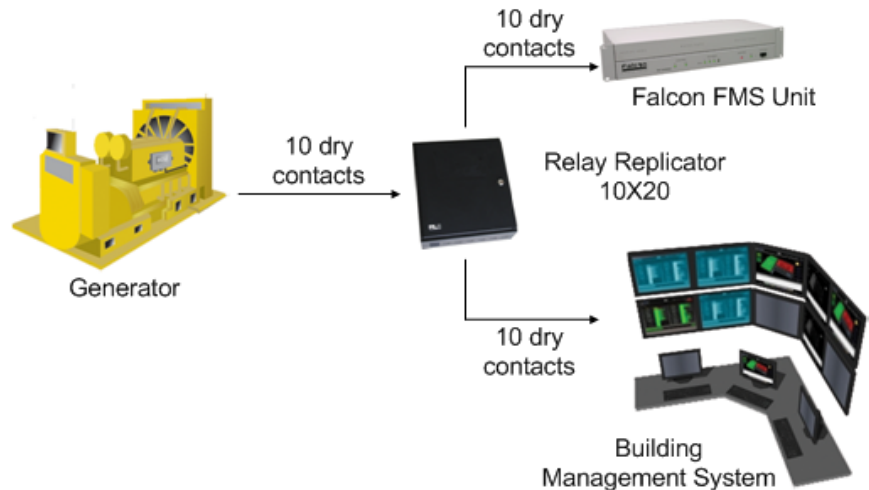

**Note:** Other voltages available upon request.

## Relay Replicator Specifications

<b>Power</b>	
RR10x20	24VAC/VDC ( $\pm 10\%$ ) @ 500mA max.; requires power supply: PSWA-DC-24 (not included)
RR10x20-48	48VAC/VDC ( $\pm 10\%$ ) @ 250mA max.; requires power supply (not included)
RR20x40	100/120/240VAC @ 500mA max., 50/60Hz; hardwired power supply
<b>Relay Outputs</b>	
RR10x20	20 Form A, 1A @24VDC, 0.5A resistive @120VAC
RR20x40	40 Form A, 1A @24VDC, 0.5A resistive @120VAC
<b>Isolation</b>	1000Vrms
<b>Operating Environment</b>	
Temperature	32°F to 122°F (0°C to 50°C)
Humidity	5% to 95% RH, non-condensing
Altitude	15,000ft (4,572m) max..
<b>Storage Environment</b>	-4F to 158°F (-20°C to 70°C)
<b>Dimensions</b>	
RR10x20	10.5"W x 8.0"H x 2.0"D (267mmW x 203mmH x 51mmD)
RR20x40	12.0"W x 14.0"H x 4.0"D (305mmW x 356mmH x 102mmD)
<b>Weight</b>	
RR10x20	5.0 lbs. (2.27kg)
RR20x40	12.0 lbs (5.45kg)
<b>Mounting</b>	Vertical wall mount
<b>Certifications</b>	CE; ETL listed: conforms to UL STD 61010-1, EN STD 61010-1; certified to CSA C22.2 STD NO. 61010-1

# Raptor

Although the information contained in this document is believed to be accurate and correct, RLE Technologies assumes no responsibility, and disclaims all liability, for any damages resulting from the use of this information or any error or omission in this document. RLE Technologies does not warrant, guarantee, or make any representations as to the performance, fitness for use, safety, or reliability of any existing or future wiring, equipment, additions or modifications to equipment, or any other component of the original or modified system. Specifications are subject to change without notice.

120051 Rev 3.1 (1/2011) ©2011 RLE Technologies

**RLE**  
Technologies

104 Racquette Drive  
Fort Collins, CO 80524  
970.484.6510  
www.rletech.com