

Relay Replicator Quick Start Guide



Thank you for purchasing the Raptor Relay Replicator (RR). This guide describes how to install the Relay Replicator.

If you need further assistance, contact RLE Technologies on our website at <http://www.rletech.com/> (go to the **Support Link**) or by calling **970.484.6510, Option 2.**



1 Introduction to the Relay Replicator

The Relay Replicator converts single dry contact signals into multiple isolated dry contact signals. The dry contact signal can then be routed to multiple systems or devices. Each input causes a relay on the Relay Replicator to either activate or deactivate depending upon the input contact state. In turn, the Relay Replicator provides two outputs for each input. The relays provide 1,000V of electrical isolation. The Relay Replicator is jumper configurable to select inputs with either a positive or negative common.

The Relay Replicator is available in RR10x20 and RR20x40 configurations. These products come in a metal enclosure that can be wall mounted. The RR10x20 contains one circuit board with 10 DPST relays. The RR20x40 uses two circuit boards.

2 Installation

The Relay Replicator is a wall-mounted device. To secure the device to the wall:

- 1 Remove the aluminum back panel and all electronics from the enclosure.
- 2 Remove as many knockouts as necessary from the top and bottom of the enclosure to accommodate 0.5 inch (12.7mm) conduit.
- 3 Insert drywall anchors through the four holes in the back of the unit to secure the unit to the wall.
- 4 Reinstall the back panel and reconnect the electronics.

3 Power

Use the appropriate power supply for your Relay Replicator configuration:

RR10x20: External 24VDC/VAC (part #PSWA-DC-24-ST or WA-AC-24-ST) or 48VAC/VDC (RR5x10-48 and RR10x20-48) power supply.

RR20x40: External 85-264VAC, 50/60Hz power input. (The RR20x40 is hardwired.)



A dedicated circuit breaker must be provided in the building within close proximity to the RR20x40, and be clearly marked as the disconnecting device for this unit.

4 Connections and Settings

- 1 Whenever possible, connect the inputs by installing the necessary jumpers. Using jumpers greatly reduces the number of wires that are terminated on the boards.
- Note:** The terminal blocks will only accept two 20AWG wires.
- 2 Make sure the jumpers for channels 1 through 5 (JP1 through JP11) are all set for either a positive (POS, P) or negative (NEG, N) common. If the unit is a 10x20 model, make sure the jumpers for channels 6 through 10 (JP12 through JP22) are all set for either a positive (POS, P) or negative (NEG, N) common.

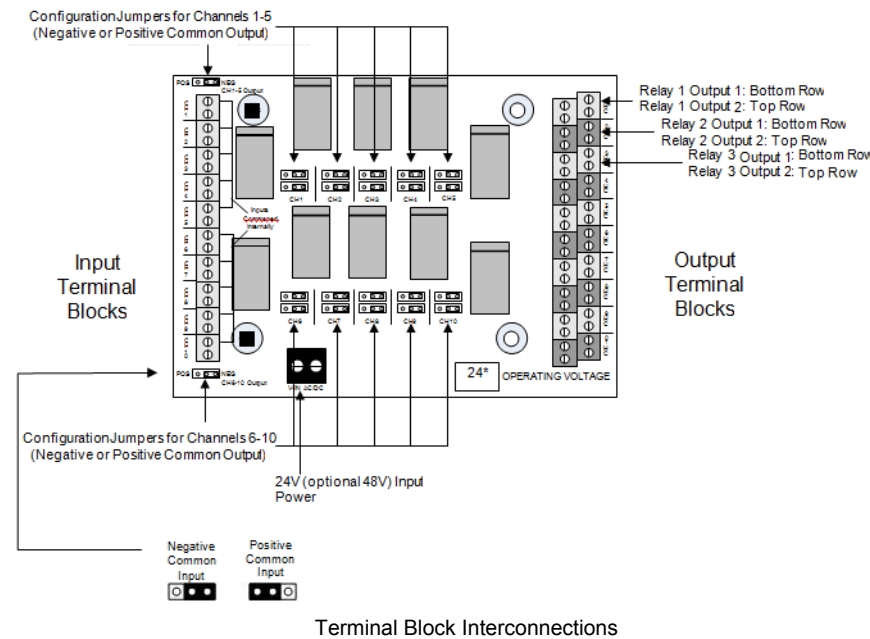

Note: 24V is normal operation voltage, with a 48V option. Check the voltage of your unit before connecting to a power source.

5 Typical Applications

The Relay Replicator contains two isolated dry contact outputs from one relay. When the dry contact activates or changes state, the Relay Replicator provides two isolated dry contact outputs.

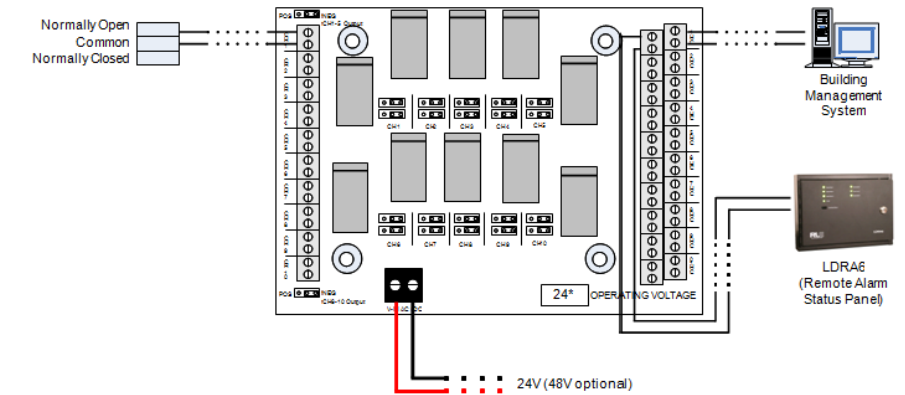

RR10x20 Configured for Negative Common (Using Dry Contact Inputs)

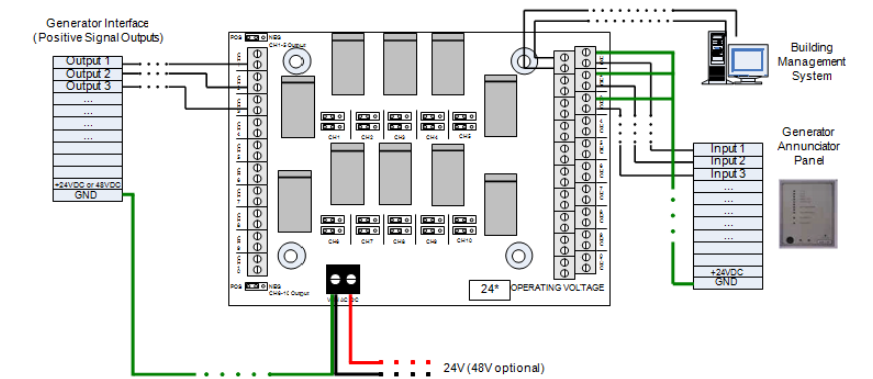

RR10x20 Configured for Positive Common (Using One Wire Interface)

6 Sample Circuits

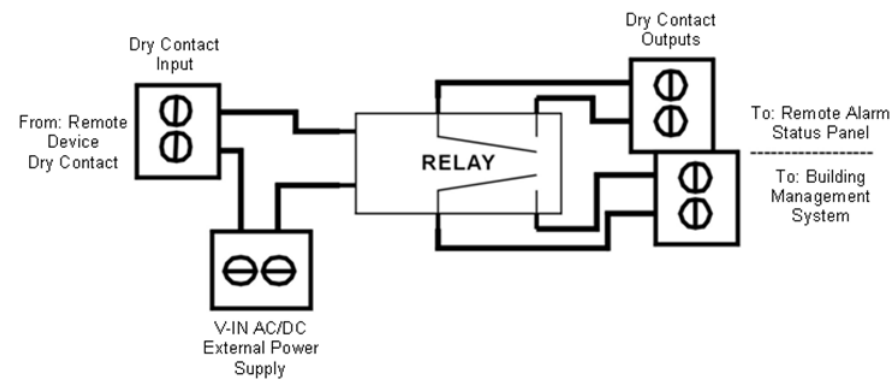
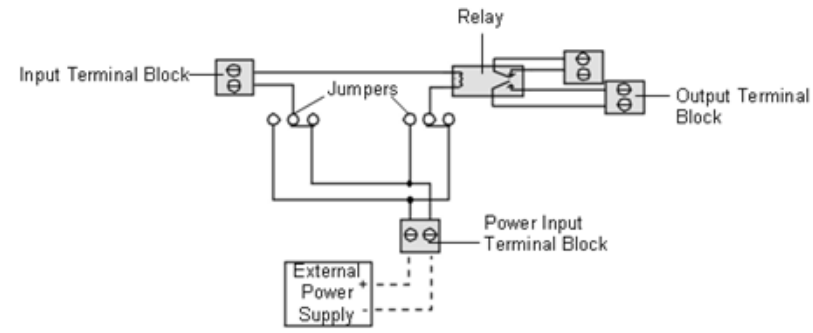

Common Polarity Configured with Jumpers

7 Illustration of Application

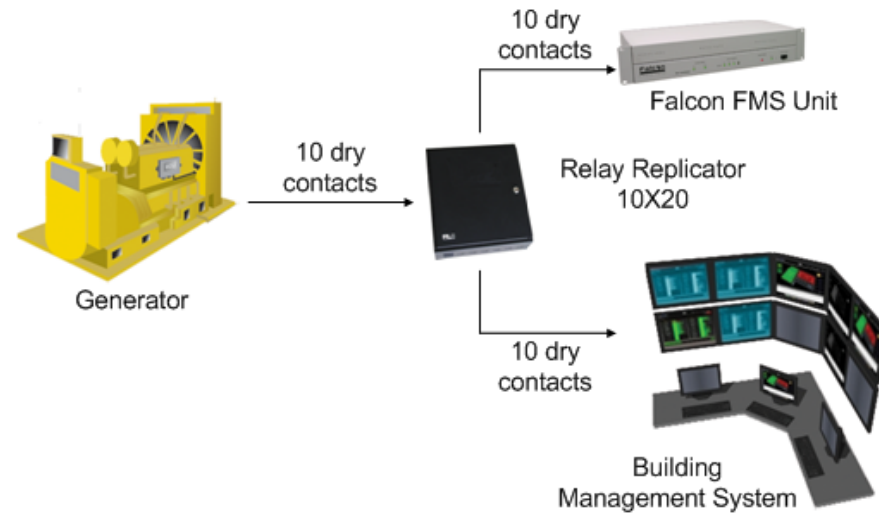

Scenario

A generator has ten dry contact outputs. A facility manager wants to wire these dry contact outputs to a Falcon FMS unit and to the building management system (BMS).

Solution

A 10x20 Relay Replicator suits this application.

The ten dry contact outputs are wired from the generator to the RR10x20. The RR10x20 provides two electrically isolated digital dry contact outputs for each dry contact input from the generator. Ten outputs are wired to the Falcon FMS unit and ten to the BMS.

Note: Other voltages available upon request.

8 Schematic

