

Installation Instructions
HW SERIES Wall Mount Digital
 RH & RH/T Transmitters (non-display models)
 1%, 2% NIST, 2%, 3% EMS
 5% VALUE

VERIS INDUSTRIES

PORTLAND, OREGON USA
 (503) 598-4564 FAX (503) 598-4664
 1-800-354-8556
<http://www.veris.com> email:sales@veris.com



- Read instructions thoroughly prior to install
- This product is not intended for life or safety applications

Applications shown are suggested means of installing sensors, but it is the responsibility of the installer to ensure that the installation is in compliance with all national and local codes. Installation should be attempted only by individuals familiar with codes, standards, and proper safety procedures for control installations.

INSTALLATION INSTRUCTIONS

Sensor Location and Backplate Mounting

Select a mounting location with good air circulation away from ventilation inlets, doors, windows, or other fresh air entry points. For room installation, the sensor should be mounted at least 4-1/2 feet above the floor.

The backplate may be flush mounted on a wall, or mounted on a standard US or European single gang junction box. Punch out openings in the backplate for wiring as required, and use the backplate as a template for locating holes for screws and wiring. Mount the backplate using screws provided. Wall anchors are recommended for drywall installations.



1

Note: Sensor must be mounted to vertical surface to ensure proper ventilation.

Backplate Wiring

Install wiring into terminal blocks as indicated, and push slack wire back into wall or junction box.

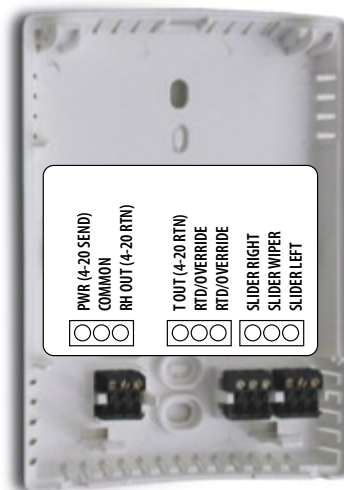

2

WARNING: Applying power to output terminal may cause permanent damage!

Sensor Installation

Carefully align top of sensor assembly to mounting plate and close as shown. Press firmly to ensure terminal pins and housing latches are fully engaged. Select switch positions for desired configuration.

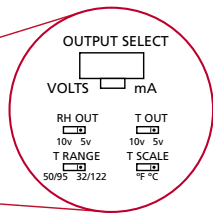

3

WARNING: Output select must be correct before applying power.

Cover Installation

Install cover plate as shown. Cover plate may be removed using a screwdriver as needed to access switch and jumpers for setup.



4

WIRING DIAGRAMS

Current Output (2-Wire, 4-20mA)

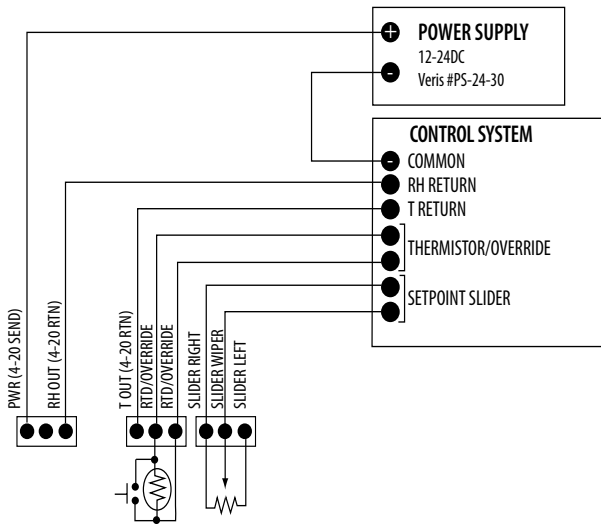

Voltage Output (3-Wire, 0-10V)

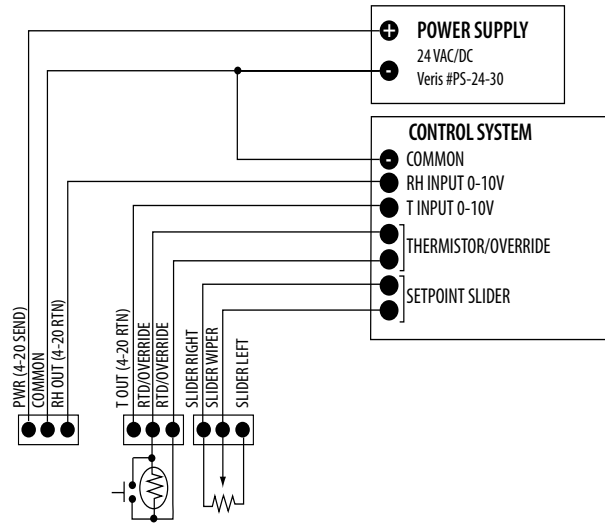

CONFIGURATION

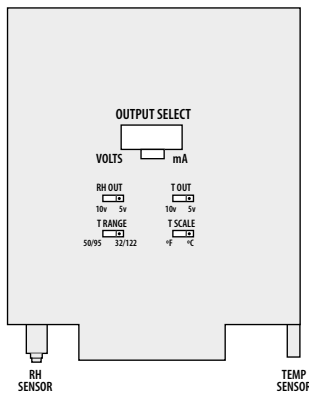

DIMENSIONAL DRAWINGS

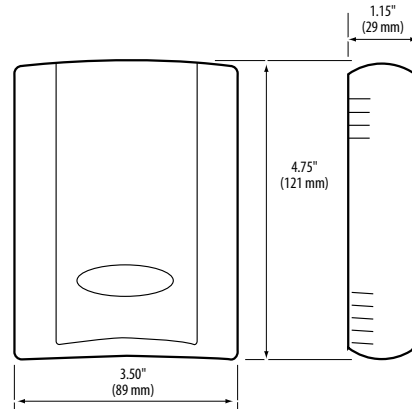

SPECIFICATIONS

HS Element.....	Digitally profiled thin-film capacitive (32 bit mathematics)U.S. Patent 5,844,138
Accuracy	±1, ±2%, 3%, or 5% (specify) @ 10 to 90% RH; Multi-point calibration NIST traceable
Reset Rate*	24 hours
Stability	±1% @ 20°C (68°F) annually, for two years
Operating Humidity Range	0 to 100% RH
Temperature Coefficient	+0.1% RH/°C below 25°C; -0.1% RH/°C above 25°C
Analog Output	4-20 mA mode; 2-wire, non-polarity sensitive
.....	0-5V/0-10 V mode; 3-wire, observe polarity
Scaling	0-100% RH
Input Power	4-20 mA mode; loop powered 12-24 VDC only, 30 mA max.
.....	0-5V/0-10 V mode; 12-24 VDC, 15 mA max.

Optional Temperature Output

T Models.....Digital, 4-20 mA or 0-5V/0-10V output; resolution/accuracy ±0.25°C (±0.45°F)
Range specified on sensor

RTD Models.....Customer specified thermistor or RTD

Conformance.....EMC EN 50081-1, EN 50082-1, EN 61000-4-4, EN 61000-4-5, EN 61000-4-3, ENV 50204, EN 61000-4-6

One side of transformer secondary is connected to signal common. Isolation transformer or dedicated power supply may be required. To conform to EMC standards, shielded cabling and technical information is available from factory upon request or is available on our website: www.veris.com

*Reset Rate is the time required to recover to 50% RH after exposure to 90% RH for 24 hours.